

**【Summarize】**

IES5028-4GS series is managed industrial Ethernet switch. The IES5028-4GS-P (100/240VAC) industrial Ethernet switches consists of 24 Ethernet ports and 4 gigabit optical ports. The IES5028-4GS-2F-P (100/240VAC) consists of 22 Ethernet ports, 2 Fiber ports and 4 gigabit optical ports. The IES5028-4GS-4F-P (100/240VAC) consists of 20 Ethernet ports, 4 Fiber ports and 4 gigabit optical ports. The IES5028-4GS-8F-P (100/240VAC) consists of 16 Ethernet ports, 8 Fiber ports and 4 gigabit optical ports. The IES5028-4GS-12F-P (100/240VAC) consists of 12 Ethernet ports, 12 Fiber ports and 4 gigabit optical ports. The IES5028-4GS-12F-P (100/240VAC) consists of 12 Ethernet ports, 12 Fiber ports and 4 gigabit optical ports. The IES5028-4GS-16F-P (100/240VAC) consists of 8 Ethernet ports, 16 Fiber ports and 4 gigabit optical ports. The IES5028-4GS-24F-P (100/240VAC) consists of 24 Fiber ports and 4 gigabit optical ports that provide an economical solution for your industrial Ethernet connection.

The IES5028-4GS series switches have an operating temperature range of -40 to 75°C, and are designed with low consumption and without fan. The rugged hardware design makes the IES5028-4GS perfect for ensuring that your Ethernet equipment can withstand the rigors of industrial applications.

SW-Ring<sup>™</sup> is designed as rapid redundancy network arithmetic. It provided recover technology for fault of rapid redundant network, the recovery time<20ms.

**【Packing list】**

Please check the packaging and accessories by your first using.

- Industrial Ethernet switch × 1
- User manual × 1
- CD × 1
- Certificate of quality × 1
- Warranty card × 1

Please inform us or our distributor if your equipments have been damaged or lost any accessories, we will try our best to satisfy you.

**【Feature】****High performance network exchange technology**

- Support IEEE802.3, IEEE802.3u, IEEE 802.3x IEEE802.1Q, IEEE802.1p, IEEE802.1D, IEEE802.1W
- Support 8K MAC address
- Support 12.8Gbps backboard bandwidth
- Support flow statistics
- 10/100BaseT(X)(RJ45)
- Store and Forward switching process type
- Plug-and-play , auto MDI/MDI-X connection
- Support auto negotiation speed, F/H duplex mode, and auto send data control
- SW-Ring ring network patent technology (Fault recovery time<20ms)
- Support WEB configuration
- Support MAC address learning, aging automatic
- Support port status display, data update.
- Support RSTP, IGMP, port trunking and port mirroring
- Support rate control, Broadcast storm control
- Support 1 channel relay alarm output

**Reliable Industrial grade design**

- Industrial grade 4 design, -40-75°C work temperature
- No fan deign
- IP30 protection grade
- 19 inch rack mounting

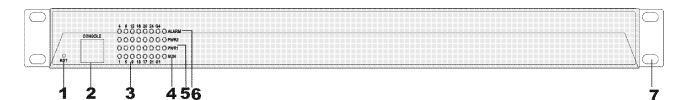
**【Panel layout】****IES5028-4GS-P (100/240VAC)****Front panel****IES5028-4GS series****Managed Industrial Ethernet switch****User manual**

### Rear panel



1. Restore factory settings
2. Console port
3. Link/ACT LEDs
4. Systems running LED
5. The power LED
6. Relay alarm LED
7. Hanger
8. Power input and Relay output terminal block
9. 1000Base-FX SFP port
10. 10/100BaseT(X) (RJ45) ports
11. Rear panel connector LEDs

### IES5028-4GS-2F-P (100/240VAC)

#### Front panel

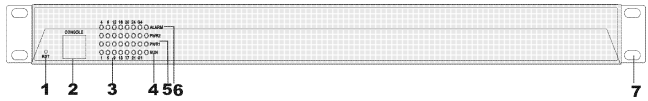

#### Rear panel

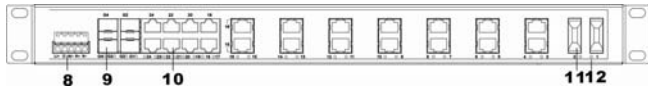

1. Restore factory settings
2. Console port
3. Link/ACT LEDs
4. Systems running LED
5. The power LED
6. Relay alarm LED
7. Hanger
8. Power input and Relay output terminal block
9. 1000Base-FX SFP port
10. 10/100BaseT(X) (RJ45) ports
11. 100Base-FX ports
12. Rear panel connector LEDs

### IES5028-4GS-4F-P (100/240VAC)

#### Front panel

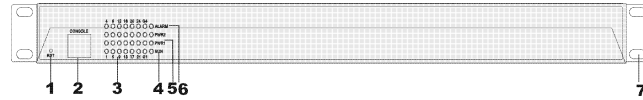

#### Rear panel

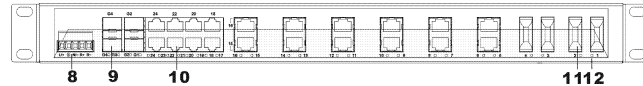

1. Restore factory settings
2. Console port
3. Link/ACT LEDs
4. Systems running LED
5. The power LED
6. Relay alarm LED
7. Hanger
8. Power input and Relay output terminal block
9. 1000Base-FX SFP port
10. 10/100BaseT(X) (RJ45) ports
11. 100Base-FX ports
12. Rear panel connector LEDs

### IES5028-4GS-8F-P (100/240VAC)

#### Front panel

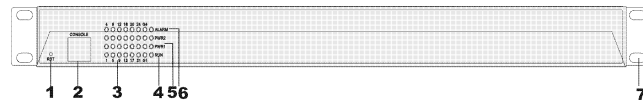

#### Rear panel

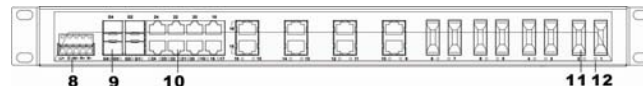

1. Restore factory settings
2. Console port
3. Link/ACT LEDs
4. Systems running LED
5. The power LED
6. Relay alarm LED

7. Hanger
8. Power input and Relay output terminal block
9. 1000Base-FX SFP port
10. 10/100BaseT(X) (RJ45) ports
11. 100Base-FX ports
12. Rear panel connector LEDs

### IES5028-4GS-12F-P (100/240VAC)

#### Front panel

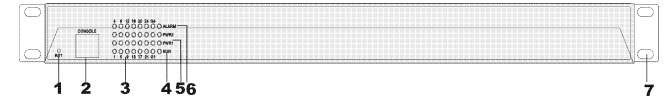

#### Rear panel

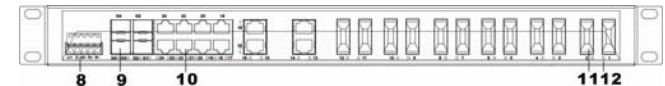

1. Restore factory settings
2. Console port
3. Link/ACT LEDs
4. Systems running LED
5. The power LED
6. Relay alarm LED
7. Hanger
8. Power input and Relay output terminal block
9. 1000Base-FX SFP port
10. 10/100BaseT(X) (RJ45) ports
11. 100Base-FX ports
12. Rear panel connector LEDs

### IES5028-4GS-16F-P (100/240VAC)

#### Front panel

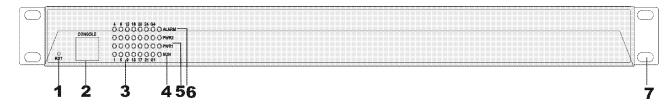

#### Rear panel

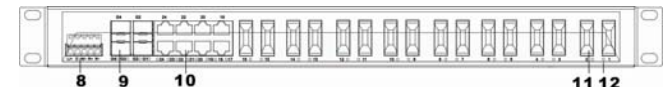

1. Restore factory settings
2. Console port
3. Link/ACT LEDs
4. Systems running LED
5. The power LED
6. Relay alarm LED
7. Hanger
8. Power input and Relay output terminal block
9. 1000Base-FX SFP port
10. 10/100BaseT(X) (RJ45) ports
11. 100Base-FX ports
12. Rear panel connector LEDs

### IES5028-4GS-24F-P (100/240VAC)

#### Front panel



#### Rear panel

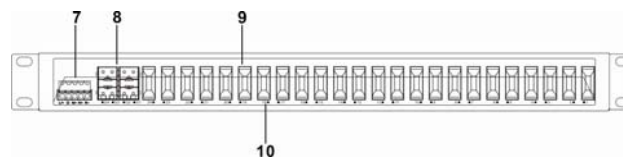

1. Restore factory settings
2. Console port
3. Link/ACT LEDs
4. Systems running LED
5. Relay alarm LED
6. The power LED
7. Power input and Relay output terminal block
8. 1000Base-FX SFP port
9. 100Base-FX ports
10. Rear panel connector LEDs

### 【Power supply input】

The series rear panel provides 3 bit wiring terminal for AC100~240V power entered. Terminal diagram is as follows:

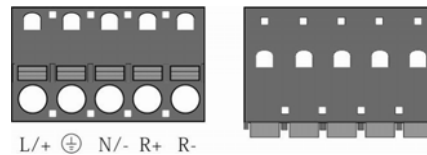

Important notice:

1. Power ON operation: first of all, insert power cable's terminal block into device's power port, then insert power supply plug into power source
2. Power OFF operation: First off all, unpin power plug, then strike the terminal block, please take care of operation sequence.

### 【Console port】

This series product provided 1pcs procedure test port based in serial port. It adopts RJ45 interface, located in top panel, can configure the CLI command through RJ45 to DB9 female cable.

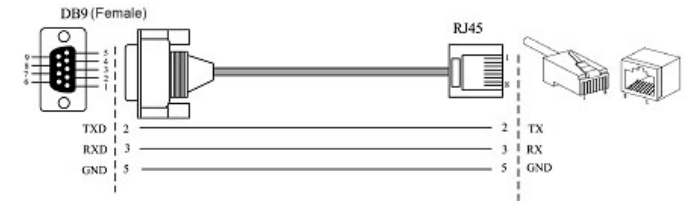

### 【Appearance and dimension】

This series of dimensions length width height, between product series port number is different.

Unit (mm)

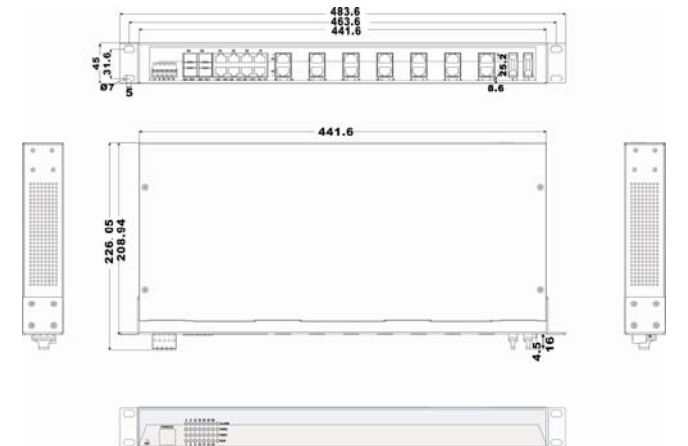

### 【Relay connection】

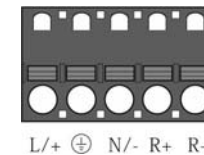

Relay access terminals in the rear panel of the device, next to the power input parts, R+ and R- are in the middle of the relay alarm output section. It is used to detect both power failure and port failure. The open circuit state in normal non alarm state, when

### IES5028-4GS-20F-P (100/240VAC)

#### Front panel



#### Rear panel

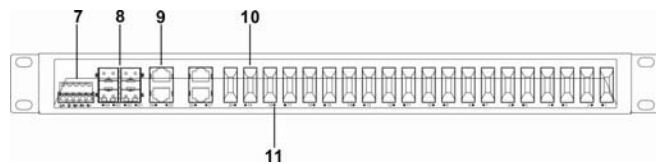

1. Restore factory settings
2. Console port
3. Link/ACT LEDs
4. Systems running LED
5. Relay alarm LED
6. The power LED
7. Power input and Relay output terminal block
8. 1000Base-FX SFP port
9. 10/100BaseT(X) ports
10. 100Base-FX ports
11. Rear panel connector LEDs

there is any alarm information to the closed state. This series of single power supply device is 1 relay alarm output, external alarm lights or alarm buzzer or external switch signal acquisition device in order to timely notify operators when an alarm occurs. (Single power supply power failure alarm is not supported)

### 【Communication connector】

#### 10/100BaseT(X) Ethernet port

The pinout of RJ45 port display as below, connect by UTP or STP. The connect distance is no more than 100m. 100Mbps is used 120Ω of UTP 5; 10Mbps is used 120Ω of UTP 3, 4, 5.

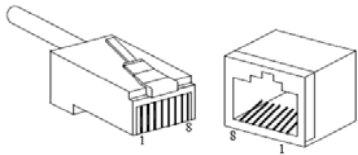

RJ 45 port support automatic MDI/MDI-X operation. Can connect the PC, Server, Converter and HUB .Pin 1,2,3,6 Corresponding connections in MDI. 1→3, 2→6, 3→1, 6→2 are used as cross wiring in the MDI-X port of Converter and HUB. 10Base-T/100Base-TX are used in MDI/MDI-X, the define of Pin in the table as below.

NO.	MDI signal	MDI-X signal
1	TX+	RX+
2	TX-	RX-
3	RX+	TX+
6	RX-	TX-
4, 5, 7, 8	—	—

Note: “TX±”Transmit Data±, “RX±”Receive Data±, “—”Not Use.

#### MDI (straight-through cable)

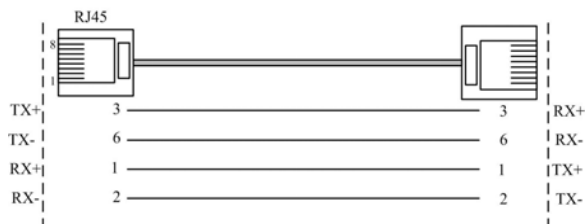

#### MDI-X (Cross over cable)

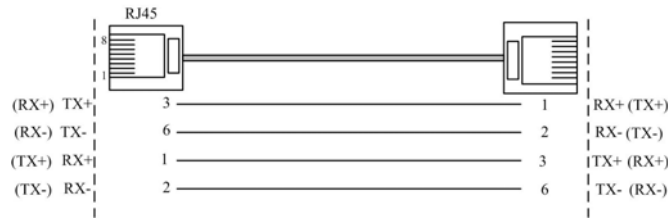

MDI/MDI-X auto connection makes switch easy to use for customers without considering the type of network cable.

#### 100Base-FX Fiber port

100Base-FX full-duplex SM or MM port, SC/ST/FC type .The fiber port must be used in pair, TX (transmit) port connect remote switch’s RX (receive) port; RX (receive) port connect remote switch’s TX (transmit) port.

The optical fiber connection supports the line to instruct enhance the reliability of network effectively.

**Suppose:** If you make your own cable, we suggest labeling the two sides of the same line with the same letter (A-to-A and B-to-B, shown as below, or A1-to-A2 and B1-to-B2).

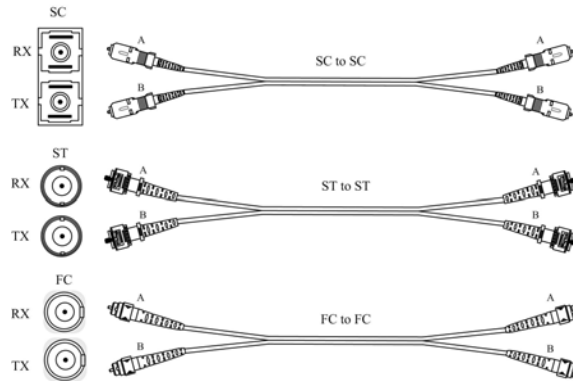

#### 1000SFP fiber port(mini-GBIC)

1000BaseSFP fiber port adopts gigabit mini-GBIC transmission, can choice different SFP module according to different transfer distance. Fiber interface must use for pair, TX port is transmit side, must connect to RX (receive side). The fiber

interface support loss line indicator.

**Suppose:** If you make your own cable, we suggest labeling the two sides of the same line with the same letter (A-to-A and B-to-B, shown as below, or A1-to-A2 and B1-to-B2).

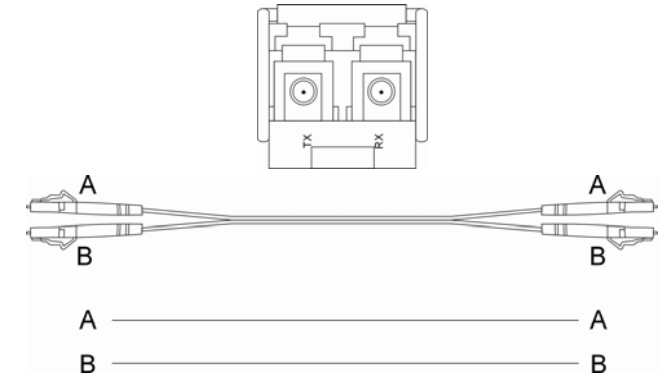

### 【LED Indicator】

LED indicator light on the front panel of product, the function of each LED is described in the table as below.

System Indication LED		
LED	State	Description
<b>PWR</b>	ON	Power is being supplied to power input PWR input
	OFF	Power is <b>not</b> being supplied to power input PWR input
<b>RUN</b>	ON/OFF	System is not running well
	Blinking	System is running well
<b>Link/ACT</b> (1~24/G1~G4)	ON	Port connection is active
	Blinking	Data transmitted
	OFF	Port connection is not active
<b>ALARM</b>	ON	Has alarm information
	OFF	No alarm information

### 【Installation】

Before installation, confirm that the work environment meet the installation require, including the power needs and abundant

space. Whether it is close to the connection equipment and other equipments are prepared or not.

1. Avoid in the sunshine, keep away from the heat fountainhead or the area where in intense EMI.
2. Examine the cables and plugs that installation requirements.
3. Examine whether the cables be seemly or not (less than 100m) according to reasonable scheme.
4. Power: 100-240VAC power input
5. Environment: working temperature: -40~75°C  
Storage Temperature: -40~85°C  
Relative humidity 5%~95%

### Rack mount installation

In most of industrial application, it is convenience to use rack mount installation, the step of installation is as follows:

1. Check if have rack mount installation tools and components (The package provided parts of components)
2. Check installation place strong or not, have the place to install the device or not.
3. Put the device into rack, aim at the screw hole of device and rack, fixed it in strong screw. Easy and convenience to operation.

### Wiring Requirements

Cable laying need to meet the following requirements,

1. It is needed to check whether the type, quantity and specification of cable match the requirement before cable laying;
2. It is needed to check the cable is damaged or not, factory records and quality assurance booklet before cable laying;
3. The required cable specification, quantity, direction and laying position need to match construction requirements, and cable length depends on actual position;
4. All the cable cannot have break-down and terminal in the middle;

5. Cables should be straight in the hallways and turning;
6. Cable should be straight in the groove, and cannot beyond the groove in case of holding back the inlet and outlet holes. Cables should be banded and fixed when they are out of the groove;
7. User cable should be separated from the power lines. Cables, power lines and grounding lines cannot be overlapped and mixed when they are in the same groove road. When cable is too long, it cannot hold down other cable, but structure in the middle of alignment rack;
8. Pigtail cannot be tied and swerved as less as possible. Swerving radius cannot be too small (small swerving causes terrible loss of link). Its banding should be moderate, not too tight, and should be separated from other cables;
9. It should have corresponding simple signal at both sides of the cable for maintaining.

### 【Specification】

#### Technology

Standard: Support IEEE802.3, IEEE802.3u, IEEE 802.3x, IEEE802.1Q, IEEE802.1p, IEEE802.1D, IEEE802.1W

Protocol: ARP、ICMP、TCP、UDP、DHCP、DNS、HTTP、Telnet、SW-Ring、RSTP、SNMP

Flow control: IEEE802.3x flow control, back press flow control

#### Function

Switch function: SW-Ring, QOS, 802.1QVLAN, RSTP, SNMP, Port trunking, static multicast filter, port mirroring, bandwidth management, broadcast storm control, port flow statistics, upgrade online, up and download configuration file, user name access system

SW-Ring: Support Single, Couple, Chain, Dual homing

#### Exchange attribute:

100M forward speed: 148810pps

1000M forward speed: 1488100pps

100M maximum filter speed: 148810pps

1000M maximum filter speed: 1488100pps

Transmit mode: store and forward

System exchange bandwidth: 12.8G

MAC address table: 8K

Memory: 4M

#### Interface

Electric port: 10Base-T/100Base-TX auto speed control, Half/full duplex and MDI/MDI-X auto detect

100M optic fiber port: 100Base-FX, SC/ST/FC connector, support single mode (20/40/60/80Km optional) , multi mode (2Km), wavelength: 1310nm, 1550nm

1000M fiber port: 1000Base-FX (SFP port)

Console port: debug serial port carry out CLI command

Alarm port: 2 bit terminal block

1 channel relay alarm output

#### Transfer distance:

Twisted cable: 100M ( standard CAT5/CAT5e cable)

Multi-mode: 1310nm, 2/5Km

Single-mode: 1310nm, 20/40/60Km

1550nm, 80/100/120Km

#### LED indicator:

Run indicator: Run

Interface indicator: Link (1~24/G1~G4)

Power supply indicator: PWR

Alarm indicator: Alarm

#### Power supply

Input voltage: 100~240VAC

Type of input: 3 bit terminal block

Overload Current Protection: 1.2A

**Consumption**

➤ IES5028-4GS-P (100/240VDC):

Unload consumption: 7.4W

Full load consumption: 13.1W

➤ IES5028-4GS-2F-P (100/240VDC):

Unload consumption: 8.7W

Full load consumption: 14.4W

➤ IES5028-4GS-4F-P (100/240VAC):

Unload consumption: 10.0W

Full load consumption: 15.7W

➤ IES5028-4GS-8F-P (100/240VDC):

Unload consumption: 12.6W

Full load consumption: 18.3W

➤ IES5028-4GS-12F-P (100/240VAC):

Unload consumption: 15.2W

Full load consumption: 20.9W

➤ IES5028-4GS-16F-P (100/240VDC):

Unload consumption: 17.8W

Full load consumption: 23.5W

➤ IES5028-4GS-20F-P (100/240VDC):

Unload consumption: 19.4W

Full load consumption: 24.1W

➤ IES5028-4GS-24F-P (100/240VAC):

Unload consumption: 22.0W

Full load consumption: 26.2W

**Working environment:**

Working temperature: -40~75℃

Storage temperature: -40~85℃

Relative Humidity: 5%~95% (no condensation)

**Mechanical Structure:**

Shell: IP30 protect grade, metal shell

Installation: 19" 1U rack

Size (W×H×D) : 441.6mm×45mm×208.9mm

**Industry Standard:**

EMI: FCC Part 15, CISPR (EN55022) class A

EMS: EN61000-4-2 (ESD) , Level 4

EN61000-4-3 (RS) , Level 3

EN61000-4-4 (EFT) , Level 4

EN61000-4-5 (Surge) , Level 4

EN61000-4-6 (CS) , Level 3

EN61000-4-8, Level 5

Shock: IEC 60068-2-27

Free fall: IEC 60068-2-32

Vibration: IEC 60068-2-6

**Certification:**

CE, FCC, RoHS, UL508 (Pending)

**Warranty:** 5 years